

8E1+4ETH
Fiber Optical Multiplexer(AR-310)

User's Manual

CONTENTS

1 General information	2
2 product character	2
3 Technical index	3
3.1 Environment requirement	3
3.2 Power supply	3
3.3 Consumption	3
3.4 E1 interface	3
3.5 10/100Base-T Port	3
3.6 RS232/Console port	4
3.7 fiber interface	4
4 Function	5
4.1panel	5
4.2 Console port	5
4.3 LED	13
4.4 Front panel DIP switches	14
4.5 Ethernet	15
4.6 Hot line phone	16
4.7 Optical interface	16
4.8 E1 interface	16
4.9 Power supply	17
5 Installation	17
5.1 Equipment installation	17
5.1.1 Quick installation	18
5.1.2 Cautions about installation	18
6 Package	20

1 General information

4/8E1+4ETH Fiber Optical Multiplexer is the 4/8E1 point-to-point optical transport equipment that uses the FPGA chips and it is easy to upgrade. It is single board structure and the largest transmission capacity is 4/8E1 and 4*100M line Ethernet data. the Ethernet bandwidth is set on base on multiple of 32K. The outer design use the standard 19 inches rack, so the volume is small, weight is light and operation is convenient and credit.

2 product character

- ✧ Provides 8 E1 transparent transmission ;
- ✧ Provide 4 100M line Ethernet channel, support mutual negotiate, Ethernet bandwidth is set on base on multiple of 32K.;
- ✧ Provide one hotline channel for option;
- ✧ The rate of optical port is 155Mbps, transmission range can reach 25KM, 40KM, 60KM, 80KM or 120KM;
- ✧ E1 interface code is HDB3 , E1 vibration characteristic conforms to ITU-T G.703、 G.823 and G.742;
- ✧ Ethernet port supports full/half duplex, 10M/100M auto-adaptable;
- ✧ Ethernet port supports VLAN function and has 4 division mode for user selection;
- ✧ Ethernet package size support 1916 byte and 4 Ethernet port could be set separately;
- ✧ Has complete alarm function and can monitor remote device status;
- ✧ Supports E1 loop from remote so as to detect and manage device conveniently;

✧ The combination AC220V and DC-48V for redundant

3 Technical index

3.1 Environment requirement

Operating temperature: -10°C ~ 60°C

Storing temperature: - 40°C ~ +85°C

Relative humidity: 95 %

3.2 Power supply

AC220V: input voltage AC 165V~250V

DC-48V: input voltage -72V~-36V

3.3 Consumption

consumption: ≤ 5W

3.4 E1 interface

Interface code: HDB3 code

Line speed: 2.048Mbps ±50ppm

Interface standard: ITU-T G 703

Interface impedance:

75Ω/unbalanced (BNC) or 120Ω/balanced RJ45

Allowed attenuation: 0~6dBm

3.5 10/100Base-T Port

Rate: 10/100M, full/duplex auto-negotiation

Protocol: Support IEEE 802.3, IEEE 802.1Q (VLAN)

MAC Address Entries: 4096 Entries

Connector: RJ45

3.6 RS232/Console port

Rate: 9600Kbps (Asynchronous)

Interface characteristic: Satisfies ITU-T V.24 standard

Connector: RJ45

3.7 fiber interface

Optical wavelength:

1310nm/1550nm for single-mode optic interface for option

850nm/1310nm for multi-mode optic interface for option

Optical interface: SC/FC/ST for option

Sending consumption: -9dBm/-5dBm

Receiving and dispatching module: >-6dBm

Optical receiver receiving sensitivity: <-36 (BER<10):

Optical code: NRZ

Transmitting range: MM 2Km/5Km,

SM 20Km/40Km/60 Km/120Km for option

4 Function

4.1 panel

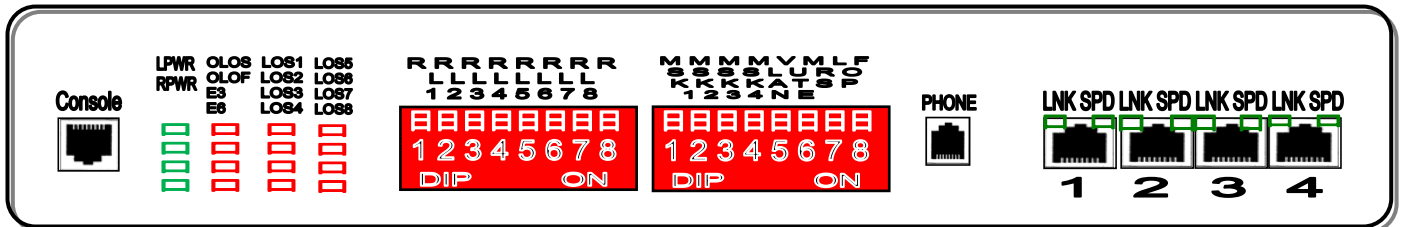

Note: for 4E1 model, the LED of LOS5~8 is invalid.

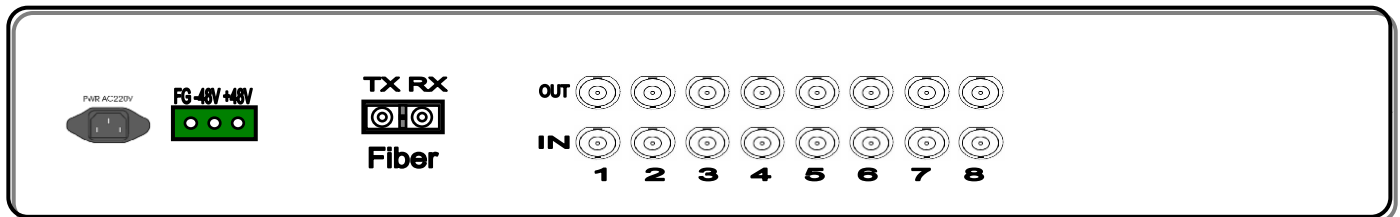

Note: for 4E1 model, there are not 5~8 BNCs.

4.2 Console port

For 4-Ethernet VLAN operation.

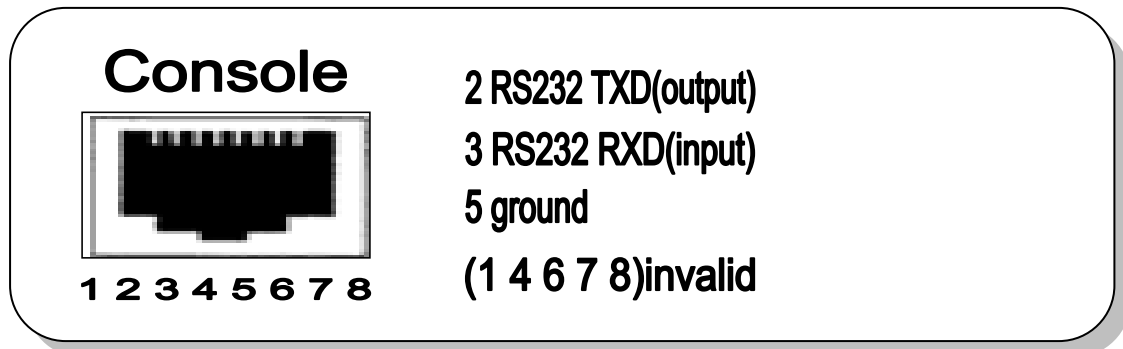

This is for PC hyper-terminal control.

Use DB9 cable to connect the PC's COM port with CONSOLE port;

Run the "hyper terminal" program under WINDOWS system, or run other third-party serial port connection software, set the default parameters as following:

Baud rate: 9600;

Data byte: 8;

parity check: none;

Stopbit: 1;

Flow control: none;

Press "ENTER" continuously for several times, enter system's CLI interface and begin management work.

```
== PDH With 4chan Ethernet Control System V2.0 ==  
===== Main Menu =====  
== 1.current Ethernet information, Please input '1'      ===  
== 2.current PDH & E1 information, Please input '2'      ===  
== 3.Enter config menu, Please input '3'                ===  
== 4.Language Switch(Chinese or English)!Please input '4' ===  
=====
```

[Future /]:

Attention: when DIP1-8 are ON, re-giving the power to the device will clean all setting record, so be attention to do like this.

Submenu introduction

1. Check etherent setting information, input "1"

```
[Future /]:1  
separate mode is:special channel separate  
Information of separate set:  
Havn't Set Separated!  
  
Information of bandwidth:  
UP PORT0:100M,00*32K
```

PORT1:100M,00*32K
PORT2:100M,00*32K
PORT3:100M,00*32K
PORT4:100M,00*32K

The device support packet sizes up to 1916!

PORT1:auto negotiation
PORT2:auto negotiation
PORT3:auto negotiation
PORT4:auto negotiation
UP PORT: MII,full duplex

802.1P Configuration:

Disable 802.1P!

Pri-value: PORT1:7 PORT2:7 PORT3:7 PORT4:7

===== Main Menu =====

== 1.current Ethernet information, Please input '1' ==

== 2.current PDH & E1 information, Please input '2' ==

== 3.Enter config menu, Please input '3' ==

== 4.Language Switch(Chinese or English)!Please input '4' ==

=====

[Future /]:

2. Check PDH&E1 information,please input"2"

[Future /]:2

Main and reserve fiber signal lost.

LOCAL/REMOTE Fiber alarm Status:

OLOS OLOF E3 E6

ALAR OK OK OK

ALAR OK OK OK

LOCAL/REMOTE E1 LOS alarm Status(L:LOS,I:Insert):

1 2 3 4 5 6 7 8

L L L L L L L L

L L L L L L L L

Hot line telephone on-hook.

Not Command the remote E1 Loop-Back.

Not Mask E1 Alarm.

Sound Alarm OFF.

Local fiber loop off.

===== Main Menu =====

== 1.current Ethernet information, Please input '1' ==

== 2.current PDH & E1 information, Please input '2' ==

== 3.Enter config menu, Please input '3' ==

== 4.Language Switch(Chinese or English)!Please input '4' ==

[Future /]:

3. Enter setting menu, please input "3"

[Future /]:3

===== Config Menu =====

== 1.Config bandwidth of device, Please input '1' ==

== 2.Set Ethernet PHY port status,Please input '2' ==

== 3.Config 802.1P,Please input '3' ==

== 4.Config 802.1Q separate,Please input '4' ==

== 5.Config 802.1Q-switcher,Please input '5' ==

== 6.Config channel separate,Please input '6' ==

== 7.Change support packet sizes(1916 or 1936),Please input '7' ==

== Exit, Please input '0' ==

[Future /Config]:

3.1 Ethernet bandwidth setting, input "1"

[Future /Config]:1

===== Bandwidth Config =====

== Set local bandwidth : setl m xyz ab (m: Port, xyz,ab: Value ==

== bandwidth =(x*100+y*10+z)M+32*(a*10+b)K (m<5,xyz<100,ab<32) ==

== Note:(1)If set Up-link bandwidth,than m=0;(Up-link is optic port) ==

== Exit, Please input '0' ==

[Future /Bandwidth config]:

X,y,z respectively denote hundred's place, decade and unit for a hundred number; a,b denote decade and unit for a ten number; m means

port number, when m=0 denote optical connector, m=1/2/3/4 denote the 1st/2nd/3rd/4th ethernet port.

If you want to set the 3rd ethernet bandwidth is 55M+32*16K, then input setl 3 055 16

3.2 Ethernet 10/100M setting, input "2"

```
[Future /Config]:2
===== Port Status Config =====
== Set command : set x y                ===
==                                     ===
== Note: x:Port numble(0<x<=5,5:UP PORT) y: 0 auto negotiation    ===
==                                     1 fored half duplex and 10BT ===
==                                     2 fored full duplex and 10BT ===
==                                     3 fored half duplex and 100BT===
==                                     4 fored full duplex and 100BT===
==                                     ===
== Exit, Please input '0'              ===
=====
[Future /Port Status Config]:
```

3.3 802.1P setting, input"3"

```
[Future /Config]:3
===== 802.1P Config =====
== 1.Enable or disable 802.1P          ===
== 802.1P user-priority command: set x y    ===
==                                     ===
== Note: x:port number(0<x<=5,5:optic port) y: value(0=<y<8)    ===
== (using this value when receive-packets havn't tag)          ===
==                                     ===
== Exit, Please input '0'              ===
=====
[Future /802.1P Config]:
```

Mark: X means 1-4ch etherent port.

Y means priority grade,inclusing:

- The highest grade is 7,applied in critical network traffic, such as routing choose information protocol(RIP) and open shortest path(OSPF)

protocol's routing table update;

- Priority 6 and 5 mainly apply in delay-sensitive program, such as interactive video and audio;
- Priority 4 to 1 mainly apply in controlled-load program, such as streaming multimedia and business-critical traffic;
- Priority 0 is default value, and start automatically without setting other priority grade.

Attention: when ethernet packet is with tag, the device will dedicate priority grade automaticly by tag; otherwise, use setting x y to set priority grade by real situation.

3.4 set based on 802.1Q, input"4"

```
[Future /Config]:4
===== 802.1Q Separate Config =====
== 802.1Q Separate set : setl x y          ===
==                                         ===
== Note: x:vlan enable(1:enable,0:disable) y: Separate modes(y = 1) ===
== Explanation of 802.1Q separate mode :    ===
== Mode1(CH1:Port1;CH2:Port2;CH3:Port3;CH4:Port4)  ===
==                                         ===
== Exit, Please input '0'                  ===
=====
[Future /802.1Q Separate Config]:
```

3.5 802.1Q switch setting, input "5"

```
[Future /Config]:5
===== 802.1Q-switcher Config =====
== Note:You can choice one of 3,4,5,and 3,4 used for back-to-back   ===
==                                         ===
== 1.Enable or disable 802.1Q                                         ===
== 2.PVID config(add this tag if packets no tag): set pvid x yyyy   ===
```

```

== Note: x:ports number(0<x<=5,5:optic port) yyyy:VID(0=<y<4096) ===
== (disable tag insertion when yyyy = 0) ===
== 3.802.1Q vlan-id config command: set vid xx yyyy ===
== Note: xx:No(0=<xx<16) yyyy:VID(0=<y<4096) ===
== 4.802.1Q membership config command: set/cir port xx y ===
== Note: xx:No(0=<xx<16) y:ports number(0<y<=5,5:optic port) ===
== e.g:vlan1:port1-3,vid=2; vlan2:port4-5,vid=3; ===
== set vid 00 0002;set vid 01 0003;set port 00 1;set port 00 2; ===
== set port 00 3;;set port 01 4;set port 01 5; ===
== 5.Clear vid and memberships,Please input '5' ===
== 6.Loop up current switcher information, Please input '6' ===
==
=====
== Exit, Please input '0' ===
=====
[Future /802.1Q-switcher Config]:

```

3.6 channel separating setting, input"6"

```

[Future /Config]:6
===== Channel Separate Config =====
== Channel Separate set : setl x y ===
==
=====
== Note: x:Channel Separate kinds ( 0=<x<4 ) ===
== y:Channel Separate modes(0<y<5) ===
== Explanation of Channel Separate Kind : ===
== Kind0( x=0 ) : Disenable Channel Separate ===
== Kind1( x=1 ) : Corresponding Channel Separated,and untagged ===
== Kind2( x=2 ) : Corresponding Channel Separated,and tagged ===
== Kind3( x=3 ) : Channel separated at local device ===
== Explanation of channel separate mode : ===
== Mode1(CH1:Port1;CH2:Port2;CH3:Port3;CH4:Port4) ===

```

```
== Mode2(CH1:Port1,Port2;CH2:Port3,Port4) (For Kind3(x=3) only) ===
```

```
== Mode3(CH1:Port1,Port2;CH2:Port3;CH3:Port4)(For Kind3(x=3) only) ===
```

```
== Mode4(CH1:Port1;CH2:Port2,Port3,Port4) (For Kind3(x=3) only) ===
```

```
==                                                    ===
```

```
== Exit, Please input '0'                               ===
```

```
=====
```

```
[Future /Channel separate config]:
```

Channel types instruction:

Type 0, when $x=0$, means cancel channel isolation;

Type 1, when $x=1$, means corresponding channel isolated, but the data has no label;

Type 2, when $x=2$, means corresponding channel isolated, but the data has label;

Type 3, when $x=3$, means the local device's ethernet channels all isolated to each other.

Attention: in ethernet transmission, the data packet is no need to add label.

But in some special network, need to add label to enhance network transmission safety.

Channel isolation instruction:

Mode 1: each channel isolates to each other;

Mode 2: consider 1st and 2nd ethernet as one transmission channel, 3th and 4th ethernet as another transmission channel;

Mode 3: consider 1st and 2nd ethernet as one transmission channel, 3th ethernet as one channel, 4th ethernet as another channel;

Mode 4: consider 1st ethernet as one channel,the other three etherent as one channel.

Attention: except mode 1, the other mode can only be applied in type 3, which is setting in local device only.

3.7 Ethernet packet switch between 1536 and 1916, input "7

```
[Future /Config]:7
Accept packet sizes form 1916 bytes to 1536 bytes!

===== Config Menu =====
== 1.Config bandwidth of device, Please input '1'      ===
== 2.Set Ethernet PHY port status,Please input '2'      ===
== 3.Config 802.1P,Please input '3'                    ===
== 4.Config 802.1Q separate,Please input '4'            ===
== 5.Config 802.1Q-switcher,Please input '5'           ===
== 6.Config channel separate,Please input '6'          ===
== 7.Change support packet sizes(1916 or 1936 ),Please input '7'  ===
== Exit, Please input '0'                               ===
=====

[Future /Config]:
```

The device has two types of packet:1916 and 1538, each ethernt port should be setted unified.

4.3 LED

LED	Color	Status	Description
LPWR	Green	On	The local device is power on.
RPWR	Green	On	The remote device is power on.
LINK	Green	On/Flick	On means connect normal, flick means date receive and transmit

100M	Green	On	Ethernet rate is 100M.
OLOS	Red	On/Flick	ON means the fiber optical signal loss. This warning will shield OLOF, E3, E6. Flick means the remote one optical signal receive error.
OLOF	red	on	Optical line frame synchronization alarm, it will shield E3, E6 alarm. When no optical signal, OLOF will shield.
E3	red	on	The line error code is over than 10^{-3} alarm, it will shield E6 alarm.
E6	red	on	The line error code is over than 10^{-3} alarm.
LOS4/8-LOS1	red	on	4/8 channel E1 signal loss.

Note: RPWR

When OLOS on, there are two different situations.

OLOS on & RPWR off: the remote one power cut.

OLOS on & RPWR on: the fiber cut.

4.4 Front panel DIP switches

DIP1-8	Name	State	Description
1	RLOP1	On	Command the remote Ch1. E1 loop back.
2	RLOP2	On	Command the remote Ch2. E1 loop back.
3	RLOP3	On	Command the remote Ch3. E1 loop back.
4	RLOP4	On	Command the remote Ch4. E1 loop back.
5	RLOP5	On	Command the remote Ch5. E1 loop back.
6	RLOP6	On	Command the remote Ch6. E1 loop back.
7	RLOP7	On	Command the remote Ch7. E1 loop back.
8	RLOP8	On	Command the remote Ch8. E1 loop back.

DIP2:

1	2	3	4	1~8E1 alarm shielding
OFF	OFF	OFF	OFF	Un-shield Ch.1~8 E1 warning
ON	ON	ON	OFF	Shield the Ch.2~8 E1 warning
ON	ON	OFF	ON	Shield the Ch.3~8 E1 warning
ON	ON	OFF	OFF	Shield the Ch.4~8 E1 warning
ON	OFF	ON	ON	Shield the Ch.5~8 E1 warning
ON	OFF	ON	OFF	Shield the Ch.6~8 E1 warning
ON	OFF	OFF	ON	Shield the Ch.7~8 E1 warning
ON	OFF	OFF	OFF	Shield the Ch.8 E1 warning
ON	ON	ON	ON	Shield all the E1s warning.

DIP2	State	Description
5(VLAN)	OFF	Forbidden VLAN setting (default)
	ON	Open the function (only for 4 Ethernet)
6(MUTE)	OFF	Unshield the warning voice (default)
	ON	Shield the warning voice
7 (LRS)	OFF	LEDs show the local device warning/ state (default)
	ON	LEDs show the remote device warning/ state
8(FOP)	OFF	Forbidden the function(default)
	ON	Command the local fiber interface loop back.

4.5 Ethernet

This multiplexer can offer 4 channels for 10/100M, full/duplex auto-negotiation LAN interface, support VLAN protocol, this interface can continuous learn MAC addresses in the LAN that connected with it, and send the address as frame in another LAN. Transparence to TCP/IP protocol, offers security connection between different equipments in the network, used widely in network connection and monitor between WAN and LAN.

- 10/100 Base-T Ethernet port parameter
- Rate: 10M or 100M, full/semi duplex auto-negotiation
- Ethernet rate in optical line: 100M.
- Protocol: support IEEE 802.3, IEEE 802.1Q(VLAN)
- MAC address table: can learn 4096 MAC address
- Ethernet buffer memory: 64Mbits SDRAM
- Physical interface: RJ45 slot, support AUTO-MDIX

Ethernet operating diagram:

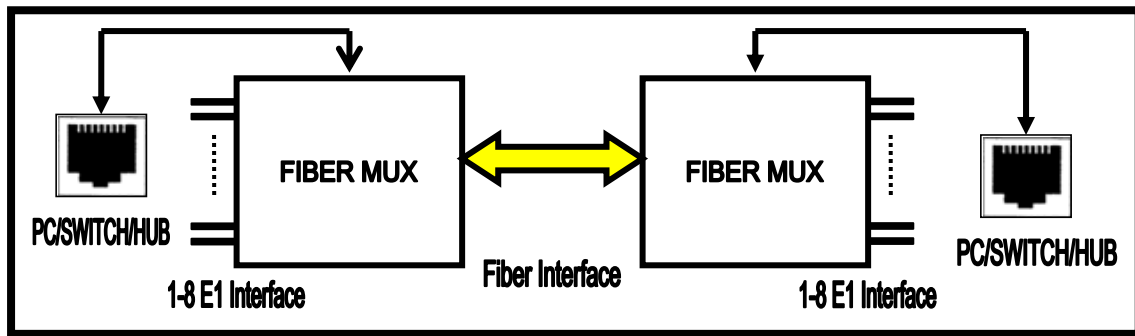

Ethernet RJ45 ports connection:

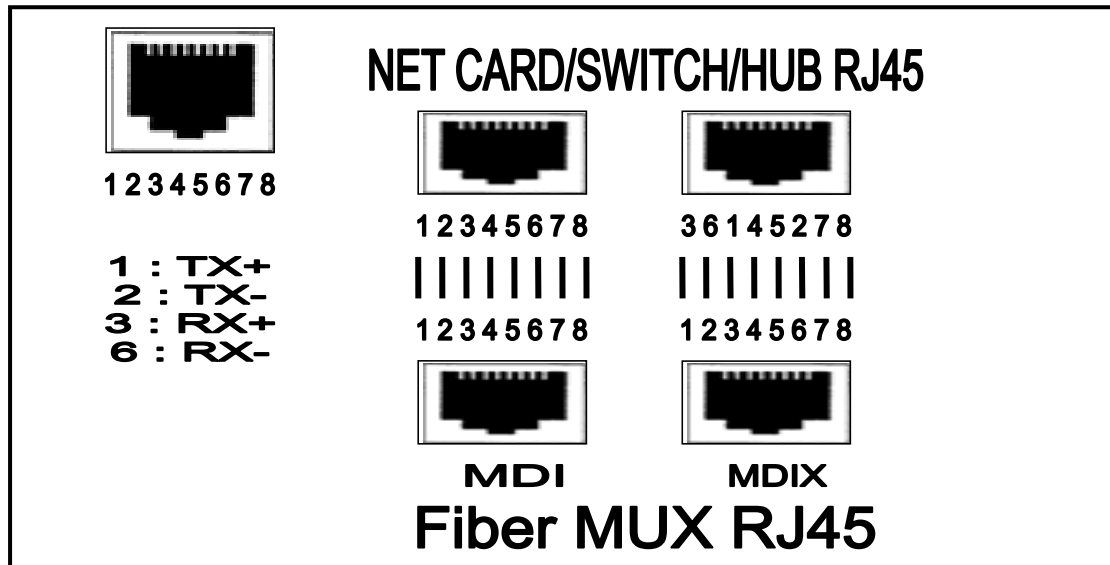

4.6 Hot line phone

Please connect to telephone set. For point-to-point application, when off-hook at any side, the other one will ring. Then the user at the other side should also off-hook to answer.

4.7 Optical interface

1. TX: Optical signal transmit
2. RX: Optical signal receive

4.8 E1 interface

It support BNC(75ohm) or RJ45 (120ohm)

RX: 75Ω unbalance E1 input

TX: 75Ω unbalance E1 output

RJ45 pins as following:

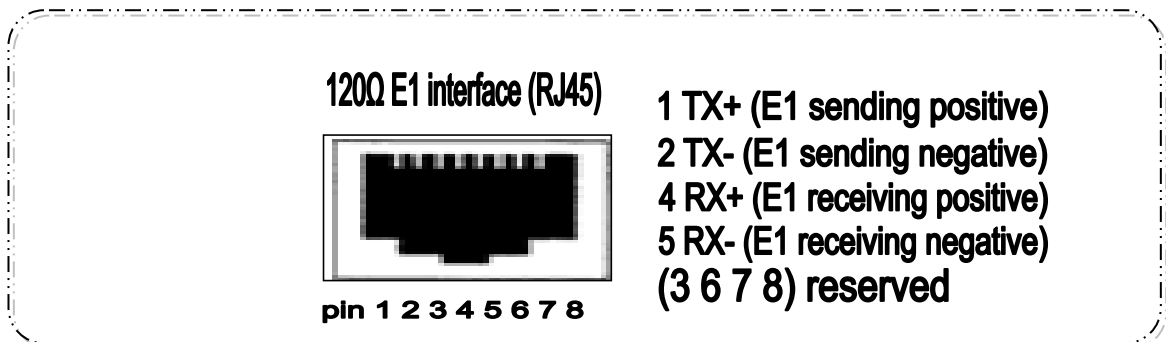

4.9 Power supply

Dual power supply: AC220V and DC-48V:

AC220V socket: input voltage range AC 165V~250V; Please insert power wire as the attachment;

DC-48V socket: input voltage DC-36V ~-72V. If the power of DC-48V is used, the positive and negative terminal can be optional because there is the self-test circuit for the polarity inside the fiber optical multiplexer.

Normal Connect way “FG” connect earth;

“-48V” connect the power negative;

“+48V” connect the power positive;

5 Installation

5.1 Equipment installation

After unpacking and before installation, make sure checking the following:

- Make sure the package is well. If the package is damaged, contact service office quickly for solution.

Check the package according to the product list, if find equipment

severe damaged or **lack** of some components, please contact installation worker or service office of us.

- Check whether the equipment type meets with the type you ordered.
- Check whether the component is in integrity.
- Check the power supply type.

5.1.1 Quick installation

- Fasten the Equipment in 19 inch rack with the screws in the equipment package.
- Use reliable ground connection at GND point of the equipment
- Use power tab to connect power according to the manual, don't exchange the polarities.
- Create user equipment connecting wire according to your demand (2M, V.35 and 10 Base-T), then connected, don't exchange receive and transfer wires.
- Connect receive and transfer optical with optical receive and transfer port of the equipment. Don't exchange receiving and transmitting wire, make sure the optical fiber head is clean, insert optical jumper, make sure connection well. (fiber bending radius \geq 50 mm)
- Use multimeter to test power polarity and voltage, make sure it matches with equipment requirement.
- After complete installation and make sure it's ok, power on the switch. Check indicator light meet with practice situation (see related part of manual).
- A clean, steady environment and firm installation should be provided for desktop or wall hanging equipment.

5.1.2 Cautions about installation

- Avoid severe liberation and mechanical damage during the process of delivering and installation.

- Arrange fiber appropriately, fiber bending radius \geq 50 mm.
- Check voltage and polarity meet with back panel, or it will cause permanent damage to the equipment.
- Fiber connector can't be contaminated, wipe optical fiber head slightly using alcohol, or it will affect transmission. If the fiber connector not butt joint well, it may be cause power decline, adjust fiber connector according to practical situation.
- The installation location should be convenient for personal passing and equipment movement.
- The environment should be dry, clean and ventilated well.
- Essential static-protective is needed during the installation and maintenance, ground the chassis to increase anti-interference capability and prevent lightning strike. Before use the equipment, independence work ground and protect ground should provided, make sure it ground well.

6 Package

Contents in each box:

4/8E1+4ETH Fiber Optical Multiplexer -----	1
AC220 Power wire -----	1
User's manual-----	1

Note:

- 4/8E1+4ETH Fiber Optical Multiplexer is a sensitive electronic item, please do handle with care when carrying or delivering and pay attention to against humidity.
- This unit will be warranted for 1 year.
- Within the warranty period, whenever there is a problem regarding the quality issue, we will take the responsibility for it and repair will done by us Free of Charge.
- After the warranty period, we will charge accordingly depending on the fault or damage.
- Whenever there is a malfunction of product, try to identify the problem according to alarm and contact our technical support in time.