

Product Features

1.25G1550nm 160KM

- Up to 1.25Gb/s dual data links
- Hot-pluggable SFP footprint
- 1550nm DFB laser transmitter
- APD Receiver
- Duplex LC connector
- Up to 160km on 9/125µm SMF
- Metal enclosure for lower EMI
- Single +3.3V power supply
- Low power dissipation <700mW
- Commercial operating temperature range: 0°C to +70°C

Applications

- Gigabit Ethernet
- 1.06 Gb/s Fibre Channel

General

160km Small Form Factor Pluggable (SFP) transceivers are compatible with the Small Form Factor Pluggable Multi-Sourcing Agreement (MSA). They simultaneously comply with Gigabit Ethernet as specified in IEEE STD 802.3 and 1x Fibre Channel as defined in FC-PI-2 Rev. 10.0 .They are RoHS compliant and lead-free.

I. Pin Descriptions

Pin	Symbol	Name/Description	Ref.
1	VeeT	Transmitter Ground (Common with Receiver Ground)	1
2	TX Fault	Transmitter Fault.	
3	TX Disable	Transmitter Disable. Laser output disabled on high or open.	2
4	MOD_DEF(2)	Module Definition 2. Data line for Serial ID.	3
5	MOD_DEF(1)	Module Definition 1. Clock line for Serial ID.	3
6	MOD_DEF(0)	Module Definition 0. Grounded within the module.	3
7	Rate Select	No connection required	
8	LOS	Loss of Signal indication. Logic 0 indicates normal operation.	4
9	VeeR	Receiver Ground (Common with Transmitter Ground)	1
10	VeeR	Receiver Ground (Common with Transmitter Ground)	1
11	VeeR	Receiver Ground (Common with Transmitter Ground)	1
12	RD-	Receiver Inverted DATA out. AC Coupled	
13	RD+	Receiver Non-inverted DATA out. AC Coupled	
14	VeeR	Receiver Ground (Common with Transmitter Ground)	1
15	VccR	Receiver Power Supply	
16	VccT	Transmitter Power Supply	
17	VeeT	Transmitter Ground (Common with Receiver Ground)	1
18	TD+	Transmitter Non-Inverted DATA in. AC Coupled.	
19	TD-	Transmitter Inverted DATA in. AC Coupled.	
20	VeeT	Transmitter Ground (Common with Receiver Ground)	1

Notes:

1. Circuit ground is internally isolated from chassis ground.
2. Laser output disabled on TX Disable >2.0V or open, enabled on TX Disable<0.8V.
3. Should be pulled up with 4.7k - 10kohms on host board to a voltage between 2.0V and 3.6V. MOD_DEF(0) pulls line low to indicate module is plugged in.
4. LOS is LVTTTL output. Should be pulled up with 4.7k – 10kohms on host board to a voltage between 2.0V and 3.6V. Logic 0 indicates normal operation; logic 1 indicates loss of signal.

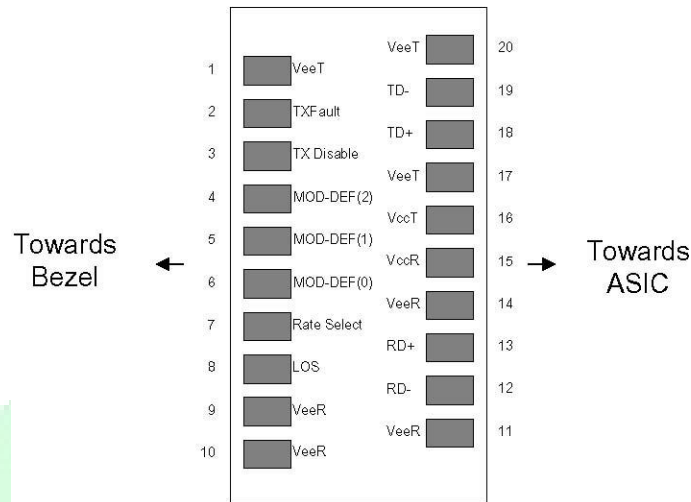

Pinout of Connector Block on Host Board

II. Absolute Maximum Ratings

Parameter	Symbol	Min	Typ	Max	Unit	Ref.
Maximum Supply Voltage	Vcc	-0.5		+4.0	V	
Storage Temperature	TS	-40		+100	°C	
Case Operating Temperature	TOP	0		+70	°C	
Relative Humidity	RH	0		85	%	1

III. Electrical Characteristics (TOP=25°C, Vcc=3.3Volts)

Parameter	Symbol	Min	Typ	Max	Unit	Ref.
Supply Voltage	Vcc	3.00		3.60	V	
Supply Current	Icc			300	mA	
Transmitter						
Input differential impedance	Rin		100		Ω	2
Single ended data input swing	Vin, pp	250		1200	mV	
Transmit Disable Voltage	VD	Vcc – 1.3		Vcc	V	
Transmit Enable Voltage	VEN	Vee		Vee+ 0.8	V	
Transmit Disable Assert Time				10	us	
Receiver						
Single ended data output swing	Vout, pp	200		800	mV	3
Data output rise time	tr			175	ps	4
Data output fall time	tf			175	ps	4
LOS Fault	VLOS fault	Vcc – 0.5		VccHOST	V	5
LOS Normal	VLOS norm	Vee		Vee+0.5	V	5

Notes:

1. Non condensing.
2. AC coupled.
3. Into 100 ohm differential termination.
4. 20 – 80 %
5. LOS is LVTTTL. Logic 0 indicates normal operation; logic 1 indicates no signal detected.
6. Measured with DJ-free data input signal. In actual application, output DJ will be the sum of input DJ and ΔDJ.

IV. Optical Characteristics (TOP=25°C, Vcc=3.3 Volts)

Parameter	Symbol	Min	Typ	Max	Unit	Ref.
Transmitter						
Output Opt. Power	PO	+2	-	+6	dBm	1
Optical Wavelength	λ	1540	-	1570	nm	
Spectral Width	σ	-	-	1	nm	
Optical Rise/Fall Time	tr/tf	-	170	260	ps	2
Deterministic Jitter Contribution	TX Δ DJ	-	-	0.07	UI	3
Total Jitter Contribution	TX Δ TJ	-	-	0.007	UI	
Optical Extinction Ratio	ER	9	-	-	dB	
Receiver						
Average Rx Sensitivity	RSSENS	-	-	-35	dBm	4
Maximum Received Power	RXMAX	-9	-	-	dBm	
Optical Center Wavelength	λ C	1270	-	1600	nm	
LOS De-Assert	LOSD	-	-	-35	dBm	
LOS Assert	LOSA	-45	-	-	dBm	
LOS Hysteresis		0.5	-	-	dB	

Notes:

1. Class 1 Laser Safety.
2. Unfiltered, 20-80%.
3. Measured with DJ-free data input signal .In actual application, output DJ will be the sum of input DJ and Δ DJ.
4. Measured with PRBS 2⁷-1 at 10⁻¹² BER .

V. General Specifications

Parameter	Symbol	Min	Typ	Max	Units	Ref.
Data Rate	BR	-	-	1250	Mb/sec	1
Bit Error Rate	BER	-	-	10 ⁻¹²		2
Max. Supported Link Length on 9/125 μ m SMF @ Gigabit Ethernet	LMAX	-	-	160	km	3,4

Notes:

1. Gigabit Ethernet and 1x Fibre Channel compliant.
2. Tested with a PRBS 2⁷-1 data pattern.
3. Dispersion limited per FC-PI-2 Rev. 10.
4. Please refer to the Optical Specifications in Table IV to calculate a more accurate link budget based on specific conditions in your application.

VI. Environmental Specifications

1550nm Commercial Temperature SFP transceivers have an operating temperature range from 0°C to +70°C case temperature.

Parameter	Symbol	Min	Typ	Max	Units	Ref.
Case Operating Temperature	Top	0		+70	°C	
Storage Temperature	Tsto	-40		+100	°C	

VII. Mechanical Specifications

Small Form Factor Pluggable (SFP) transceivers are compatible with the dimensions defined by the SFP Multi-Sourcing Agreement (MSA).

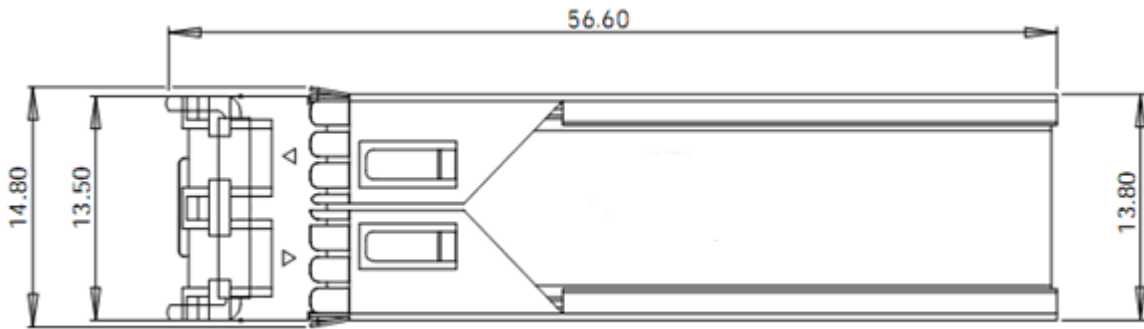
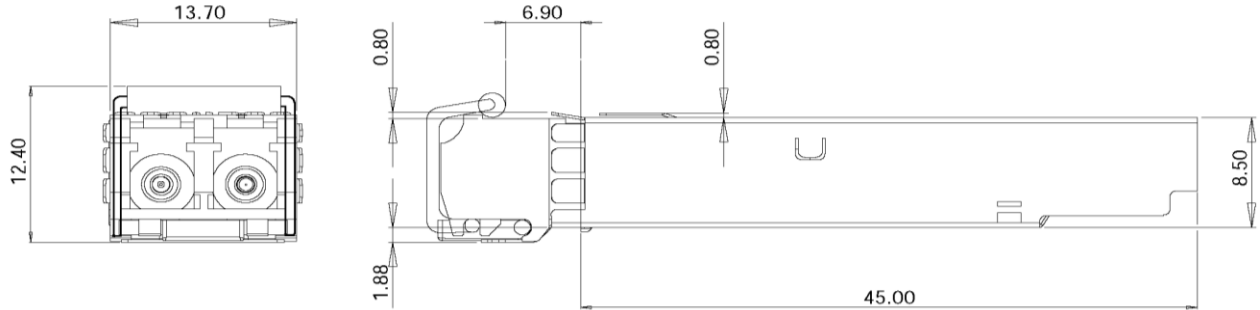

1.25G 1550nm 160KM

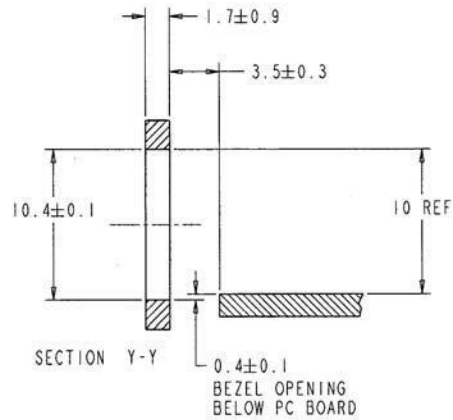
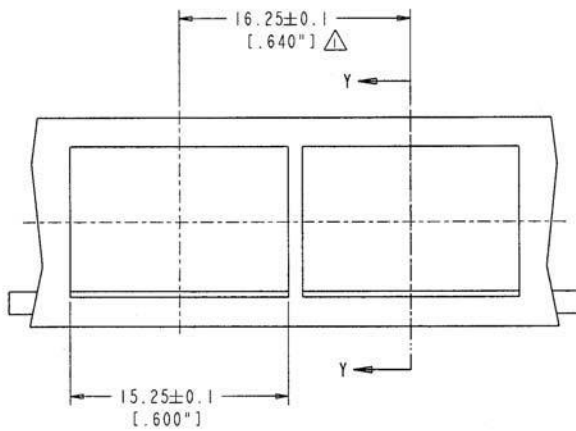
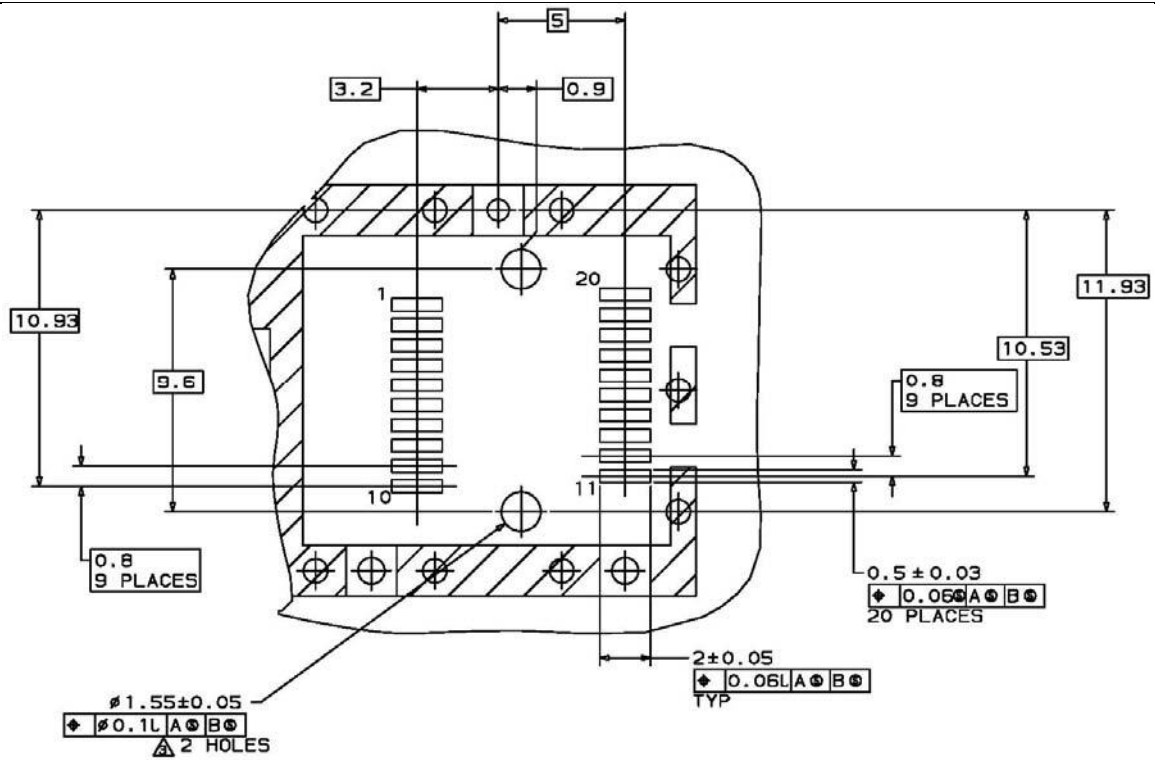

NOTES:

△ MINIMUM PITCH ILLUSTRATED, ENGLISH DIMENSIONS ARE FOR REFERENCE ONLY

2. NOT RECOMMENDED FOR PCI EXPANSION CARD APPLICATIONS