

Product Specification SFP

1.25G 80km LC

1.25Gb/s Single-mode SFP Transceiver

- Up to 80km on 9/125 μ m SMF
- Hot-pluggable SFP footprint
- Duplex LC/UPC type pluggable optical interface
- Low power dissipation
- Metal enclosure, for lower EMI
- RoHS compliant and lead-free
- Single +3.3V power supply
- Support Digital Diagnostic Monitoring interface
- Compliant with SFF-8472
- Operating case temperature: 0°C to +70°

2. Applications

- Switch to Switch Interface
- Gigabit Ethernet
- Switched Backplane Applications
- Router/Server Interface
- Other Optical Links

3. Description

A-GEAR's SFP CWDM 1G 80km LC Small Form Factor Pluggable (SFP) transceivers are compatible with the Small Form Factor Pluggable Multi-Sourcing Agreement (MSA). The transceiver consists of five sections: the LD driver, the limiting amplifier, the digital diagnostic monitor, the DFB laser and the PIN photo-detector. The module data link up to 80KM in 9/125um single mode fiber.

The optical output can be disabled by a TTL logic high-level input of Tx Disable, and the system also can disable the module via I2C. Tx Fault is provided to indicate that degradation of the laser. Loss of signal (LOS) output is provided to indicate the loss of an input optical signal of receiver or the link status with partner. The system can also get the LOS (or Link)/ Disable/Fault information via I2C register access.

4. Absolute Maximum Ratings

Parameter	Symbol	Min.	Max.	Unit
Storage Temperature	TS	-40	85	°C
Storage Ambient Humidity	HA	5	95	%
Power Supply Voltage	V _{CC}	-0.5	4	V
Signal Input Voltage		-0.3	V _{CC} +0.3	V
Receiver Damage Threshold		+7		dBm
Lead Soldering Temperature/Time	T _{SOLD}		260/10	°C/sec ^[1]
Lead Soldering Temperature/Time	T _{SOLD}		360/10	°C/sec ^[2]

Notes:

- [1] Suitable for wave soldering.
 [2] Only for soldering by iron.

5. Recommended Operating Conditions

Parameter	Symbol	Min.	Typical	Max.	Unit
Ambient Operating Temperature	TA	0		70	°C
Ambient Humidity	HA	5		70	% ^[1]
Power Supply Voltage	V _{CC}	3.13	3.3	3.47	V
Power Supply Current	I _{CC}			300	mA
Power Supply Noise Rejection				100	mVp-p ^[2]
Data Rate			1250/1250		Mbps ^[3]
Transmission Distance				80	km
Coupled Fiber					Single mode fiber 9/125um G.652

Notes:

- [1] Non-condensing
 [2] 100Hz to 1MHz
 [3] TX Rate/RX Rate

6. Specification of Transmitter

Parameter	Symbol	Min.	Typical	Max.	Unit
Average Output Power	P_{OUT}	0		5	dBm
Extinction Ratio	ER	9			dB

Parameter	Symbol	Min.	Typical	Max.	Unit
Center Wavelength	λ_C	(1XX0)-10	1XX0	(1XX0)+10	nm [1,5]

Side Mode Suppression Ratio	SMSR	30			dB
-----------------------------	------	----	--	--	----

Spectrum Bandwidth(-20dB)	σ			1	nm
---------------------------	----------	--	--	---	----

Transmitter OFF Output Power	P_{off}			-45	dBm
------------------------------	-----------	--	--	-----	-----

Differential Line Input Impedance	RIN	90	100	110	Ohm
-----------------------------------	-----	----	-----	-----	-----

Optical Rise/Fall Time	tr/tf			0.26	ns [2]
------------------------	-------	--	--	------	--------

Total Jitter	tj			120	ps [3]
--------------	----	--	--	-----	--------

Output Eye Mask Compliant with IEEE802.3 z (class 1 laser safety) [4]

Notes:

- [1] «XX» is: 27, 29, 31, 33, 35, 37, 39, 41, 43, 45, 47, 49, 51, 53, 55, 57, 59 and 61
- [2] These are unfiltered 20-80% values.
- [3] Measure at 2Λ7-1 NRZ PRBS pattern
- [4] Transmitter eye mask definition
- [5] DFB Laser

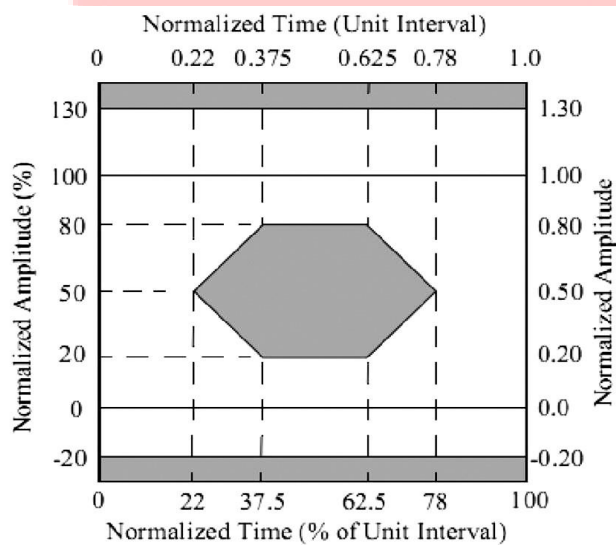

7. Specification of Receiver

Parameter	Symbol	Min.	Typical	Max.	Unit
Input Optical Wavelength	λ_{IN}	(1XX0)-10	1XX0	(1XX0)+10	nm [1,5]
Receiver Sensitivity	P_{IN}			-26	dBm [2]
Input Saturation Power (Overload)	P_{SAT}	-3			dBm
Signal Detect (Assert Power)	P_A			-27	dBm
Signal Detect (De-Assert Power)	P_D	-38			dBm [3]
Signal Detect Hysteresis	$P_A - P_D$	0.5	2	6	dB
Data Output Rise/Fall time	tr/tf			0.36	ns[4]

Notes:

- [1] «XX» is: 27, 29, 31, 33, 35, 37, 39, 41, 43, 45, 47, 49, 51, 53, 55, 57, 59 and 61.
- [2] Measured with Light source 1XX0 nm, ER=9dB; BER =10^{-12} @PRBS=2⁷-1 NRZ [3] When SD De-Assert, the RX-LOS output is High-level (fixed) [4] These are 20%~80% values. [5] PIN-TIA

8. Electrical Interface Characteristics

Parameter	Symbol	Min.	Max.	Unit
Transmitter				
Total Supply Current	I_{CC}		A	mA [1]
Transmitter Disable Input-High	V_{DISH}	2	$V_{CC}+0.3$	V
Transmitter Disable Input-Low	V_{DISL}	0	0.8	V
Transmitter Fault Input-High	V_{DISL}	2	$V_{CC}+0.3$	V
Transmitter Fault Input-Low	V_{TXFH}	0	0.8	V
Receiver				
Total Supply Current	I_{CC}		B	mA [1]
LOSS Output Voltage-High	V_{LOSH}	2	$V_{CC}+0.3$	V [2]
LOSS Output Voltage-Low	V_{LOSL}	0	0.8	V

Notes:

- [1] A (TX) + B (RX) = 280mA (Not include termination circuit)
- [2] LVTTTL

9 Pin Assignment

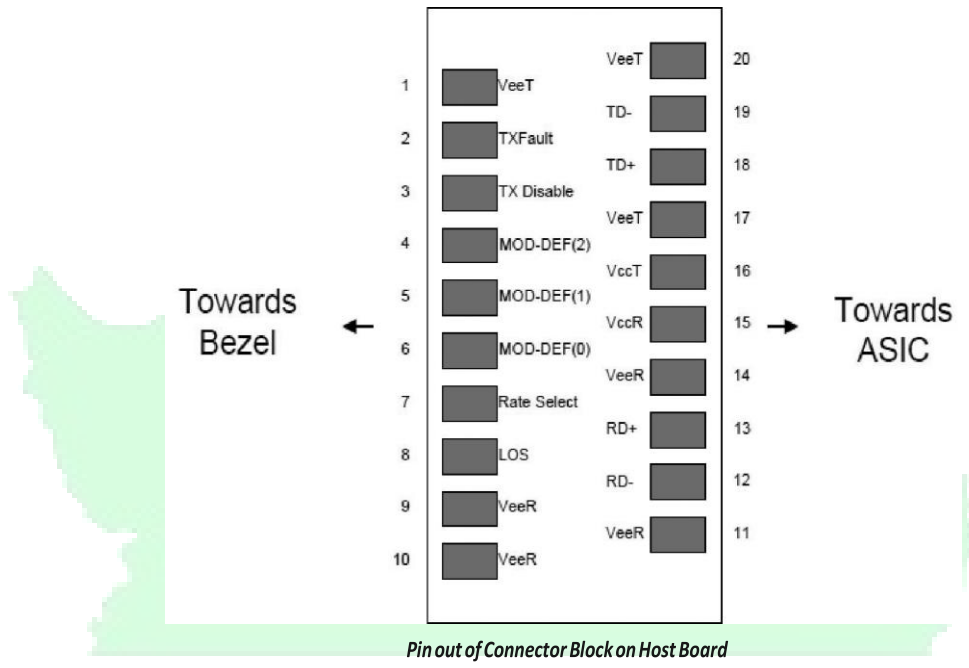

با افتخار ساخت ایران



10. Pin Descriptions

Pin	Symbol	Name/Description
1	V _{EET}	Transmitter Ground (Common with Receiver Ground) ^[1]
2	T _{FAULT}	Transmitter Fault. Not supported.
3	T _{DIS}	Transmitter Disable. Laser output disabled on high or open. ^[2]
4	MOD_DEF(2)	Module Definition 2. Data line for Serial ID. ^[3]
5	MOD_DEF(1)	Module Definition 1. Clock line for Serial ID. ^[3]
6	MOD_DEF(0)	Module Definition 0. Grounded within the module. ^[3]
7	Rate Select	No connection required ^[4]
8	LOS	Loss of Signal indication. Logic 0 indicates normal operation. ^[5]
9	V _{EER}	Receiver Ground (Common with Transmitter Ground) ^[1]
10	V _{EER}	Receiver Ground (Common with Transmitter Ground) ^[1]
11	V _{EER}	Receiver Ground (Common with Transmitter Ground) ^[1]
12	RD-	Receiver Inverted DATA out. AC Coupled
13	RD+	Receiver Non-inverted DATA out. AC Coupled
14	V _{EER}	Receiver Ground (Common with Transmitter Ground) ^[1]
15	V _{CCR}	Receiver Power Supply
16	V _{CCT}	Transmitter Power Supply
17	V _{EET}	Transmitter Ground (Common with Receiver Ground) ^[1]
18	TD+	Transmitter Non-Inverted DATA in. AC Coupled.
19	TD-	Transmitter Inverted DATA in. AC Coupled.
20	V _{EET}	Transmitter Ground (Common with Receiver Ground) ^[1]

Notes:

- [1] Circuit ground is internally isolated from chassis ground.
- [2] Laser output disabled on T_{DIS} > 2.0V or open, enabled on T_{DIS} < 0.8V.
- [3] Should be pulled up with 4.7k - 10kohms on host board to a voltage between 2.0V and 3.6V.
- [4] MOD_DEF (0) pulls line low to indicate module is plugged in.
- [5] This is an optional input used to control the receiver bandwidth for compatibility with multiple data rates (most likely Fiber Channel 1x and 2x Rates). If implemented, the input will be internally pulled down with > 30kΩ resistor. The input states are:
- | | |
|----------------------|-------------------|
| Low (0 - 0.8V): | Reduced Bandwidth |
| (>0.8, < 2.0V): | Undefined |
| High (2.0 - 3.465V): | Full Bandwidth |
| Open: | Reduced Bandwidth |
- [6] LOS is open collector output should be pulled up with 4.7k - 10kohms on host board to a voltage between 2.0V and 3.6V. Logic 0 indicates normal operation; logic 1 indicates loss of signal.

11. Digital Diagnostic Functions

A-GEAR SFP 1.25G 80km LC transceivers support the 2-wire serial communication protocol as defined in the SFP MSA. It is very closely related to the E2PROM defined in the GBIC standard, with the same electrical specifications.

The standard SFP serial ID provides access to identification information that describes the transceiver's capabilities, standard interfaces, manufacturer, and other information. Additionally, A-GEAR SFP transceivers provide a unique enhanced digital diagnostic monitoring interface, which allows real-time access to device operating parameters such as transceiver temperature, laser bias current, transmitted optical power, received optical

power and transceiver supply voltage. It also defines a sophisticated system of alarm and warning flags, which alerts end-users when particular operating parameters are outside of a factory set normal range.

The SFP MSA defines a 256-byte memory map in E2PROM that is accessible over a 2-wire serial interface at the 8 bit address 1010000X (A0h). The digital diagnostic monitoring interface makes use of the 8 bit address 1010001X (A2h), so the originally defined serial ID memory map remains unchanged. The interface is identical to, and is thus fully backward compatible with both the GBIC Specification and the SFP Multi Source Agreement.

The operating and diagnostics information is monitored and reported by a Digital Diagnostics Transceiver Controller (DDTC) inside the transceiver, which is accessed through a 2-wire serial interface. When the serial protocol is activated, the serial clock signal (SCL, Mod Def 1) is generated by the host. The positive edge clocks data into the SFP transceiver into those segments of the E2PROM that are not write-protected. The negative edge clocks data from the SFP transceiver. The serial data signal (SDA, Mod Def 2) is bi-directional for serial data transfer. The host uses SDA in conjunction with SCL to mark the start and end of serial protocol activation. The memories are organized as a series of 8-bit data words that can be addressed individually or sequentially.

Digital diagnostics for the SFP 1.25G 80km LC are internally calibrated by default.

12. Host - Transceiver Inter face Block Diagram

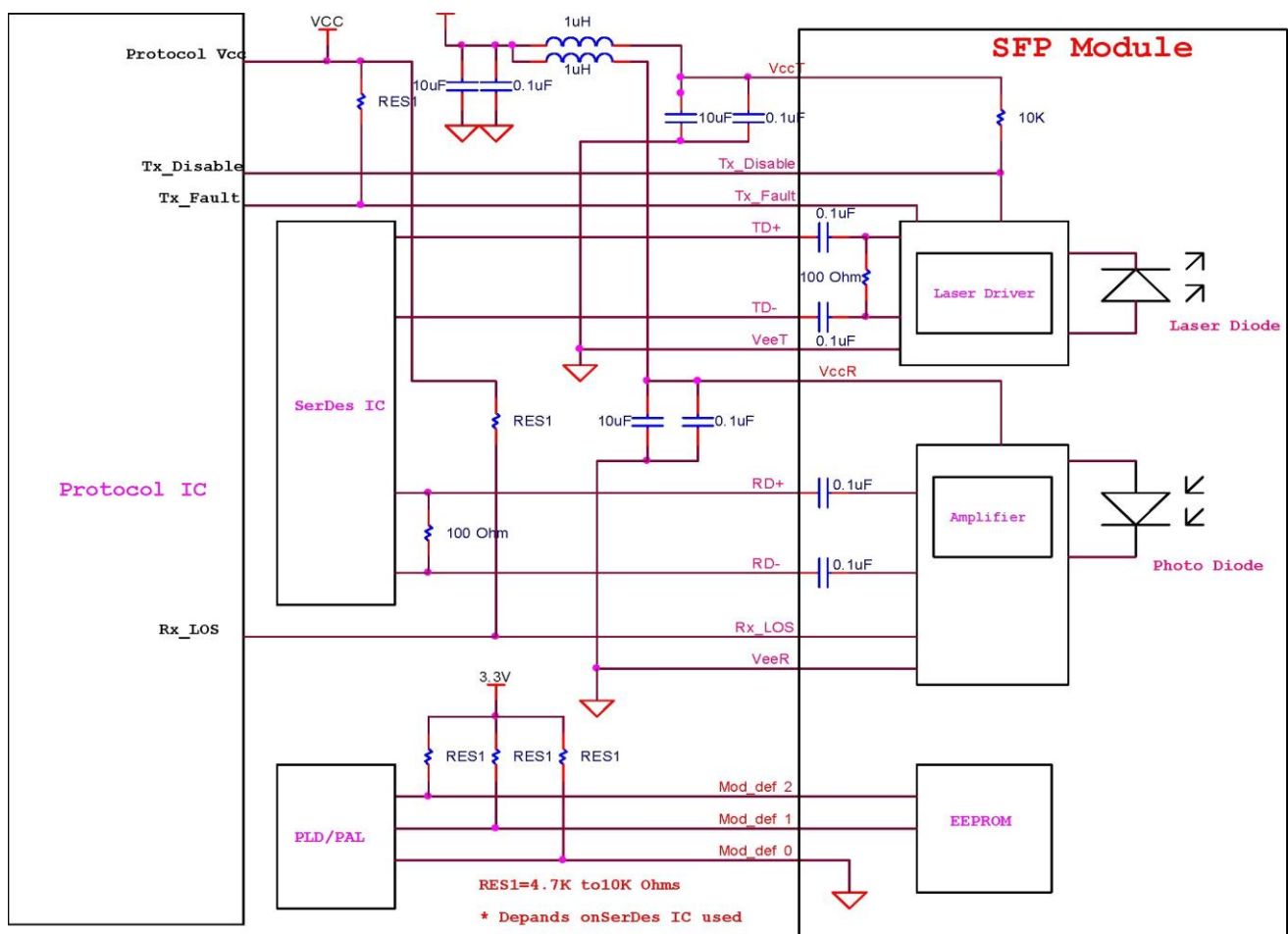

13. Outline Dimensions

Comply to SFF-8432 rev5.0, the improved Pluggable form factor specification.

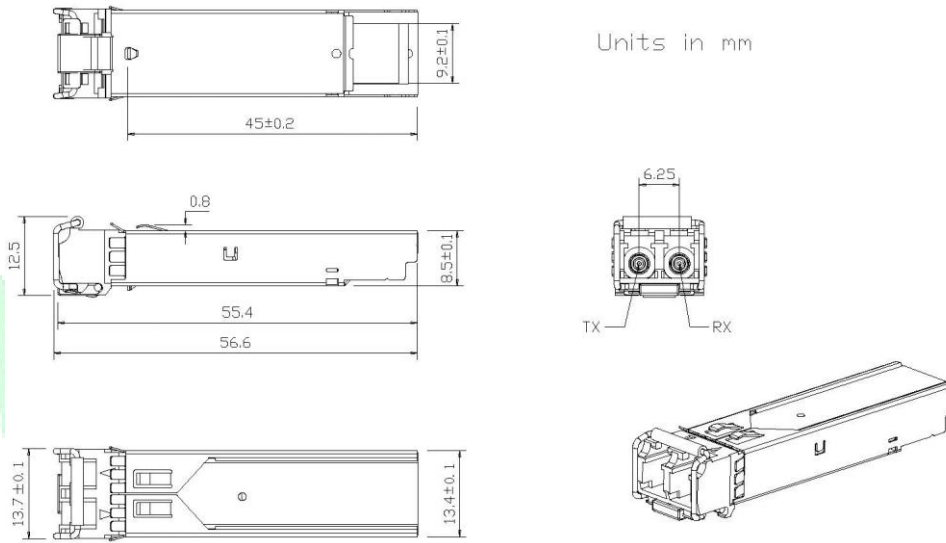

14. Regulatory Compliance

Feature	Reference	Performance
Electrostatic Discharge (ESD) to the Electrical Pins	MIL-STD-883E Method 3015.7 EIA-JESD22-A114	Class 1
Electrostatic Discharge (ESD) to the Simplex Receptacle	IEC/EN 61000-4-2	Compatible with standards
Electromagnetic Interference (EMI)	FCC Part 15 Class B EN 55022 Class B (CISPR 22A)	Compatible with standards
Laser Eye Safety	FDA 21CFR 1040.10, 1040.11 IEC/EN 60825-1 IEC/EN 60825-2	Class 1 laser product
Component Recognition	IEC/EN 60950 UL 60950	Compatible with standards
ROHS	2002/95/EC	Compatible with standards