

Product Specification Sheet

(AR-WD-XXX)

10Gb/s SFP DWDM 80km Optical Transceiver



Product Features

- Supports up to 11Gb/s bit rates
- Duplex LC connector
- Hot pluggable SFP+ footprint
- Cooled EML transmitter and APD-TIA receiver
- Applicable for 80km SMF connection
- Low power consumption, < 1.2W
- 100GHz ITU Grid, C Band

- Digital Diagnostic Monitor Interface
- Optical interface compliant to ITU-T 694.1& G.698.1
- Electrical interface compliant to SFF-8431& SFF-8432
- Operating case temperature:
 - Commerical:0 to 70 °C
 - Industrial:-40~85°C

Applications

- C Band DWDM networks
- SONET/SDH networks
- Fiber channel
- Gigabit Ethernet

Product Descriptions

Arioo AR1202 Enhanced Small Form Factor Pluggable (SFP) transceivers are compatible with the Small Form Factor Pluggable Multi-Sourcing Agreement (MSA) and SFF-8472. The transceiver consists of five sections: the LD driver, the limiting amplifier, the digital diagnostic monitor, the EML laser and the APD .The module data link up to 80KM in 9/125um single mode fiber. It offers a simple and convenient way to interface PCBs to single mode fiber optic cables in Dense Wavelength Division Multiplexing (DWDM) applications. It is a high performance, cost effective module for serial optical data communication applications.

The optical output can be disabled by a TTL logic high-level input of Tx Disable, and the system also can disable the module via I2C. Tx Fault is provided to indicate that degradation of the laser. Loss of signal (LOS) output is provided to indicate the loss of an input optical signal of receiver or the link status with partner. The system can also get the LOS (or Link)/Disable/Fault information via I2C register access.

Product Channel Selection

Channel#	Product Part No.	Frequency (THz)	Center Wavelength (nm)
17	ARD1712L-CDH2	191.7	1563.86
18	ARD1812L-CDH2	191.8	1563.05
19	ARD1912L-CDH2	191.9	1562.23
20	ARD2012L-CDH2	192.0	1561.42
21	ARD2112L-CDH2	192.1	1560.61
22	ARD2212L-CDH2	192.2	1559.79
23	ARD2312L-CDH2	192.3	1558.98

24	ARD2412L-CDH2	192.4	1558.17
25	ARD2512L-CDH2	192.5	1557.36
26	ARD2612L-CDH2	192.6	1556.55
27	ARD2712L-CDH2	192.7	1555.75
28	ARD2812L-CDH2	192.8	1554.94
29	ARD2912L-CDH2	192.9	1554.13
30	ARD3012L-CDH2	193.0	1553.33
31	ARD3112L-CDH2	193.1	1552.52
32	ARD3212L-CDH2	193.2	1551.72
33	ARD3312L-CDH2	193.3	1550.92
34	ARD3412L-CDH2	193.4	1550.12
35	ARD3512L-CDH2	193.5	1549.32
36	ARD3612L-CDH2	193.6	1548.51
37	ARD3712L-CDH2	193.7	1547.72
38	ARD3812L-CDH2	193.8	1546.92
39	ARD3912L-CDH2	193.9	1546.12
40	ARD4012L-CDH2	194.0	1545.32
41	ARD4112L-CDH2	194.1	1544.53
42	ARD4212L-CDH2	194.2	1543.73
43	ARD4312L-CDH2	194.3	1542.94
44	ARD4412L-CDH2	194.4	1542.14
45	ARD4512L-CDH2	194.5	1541.35
46	ARD4612L-CDH2	194.6	1540.56
47	ARD4712L-CDH2	194.7	1539.77
48	ARD4812L-CDH2	194.8	1538.98
49	ARD4912L-CDH2	194.9	1538.19
50	ARD5012L-CDH2	195.0	1537.40
51	ARD5112L-CDH2	195.1	1536.61
52	ARD5212L-CDH2	195.2	1535.82
53	ARD5312L-CDH2	195.3	1535.04
54	ARD5412L-CDH2	195.4	1534.25
55	ARD5512L-CDH2	195.5	1533.47
56	ARD5612L-CDH2	195.6	1532.68
57	ARD5712L-CDH2	195.7	1531.90
58	ARD5812L-CDH2	195.8	1531.12
59	ARD5912L-CDH2	195.9	1530.33
60	ARD6012L-CDH2	196.0	1529.55
61	ARD6112L-CDH2	196.1	1528.77

Functional Diagram

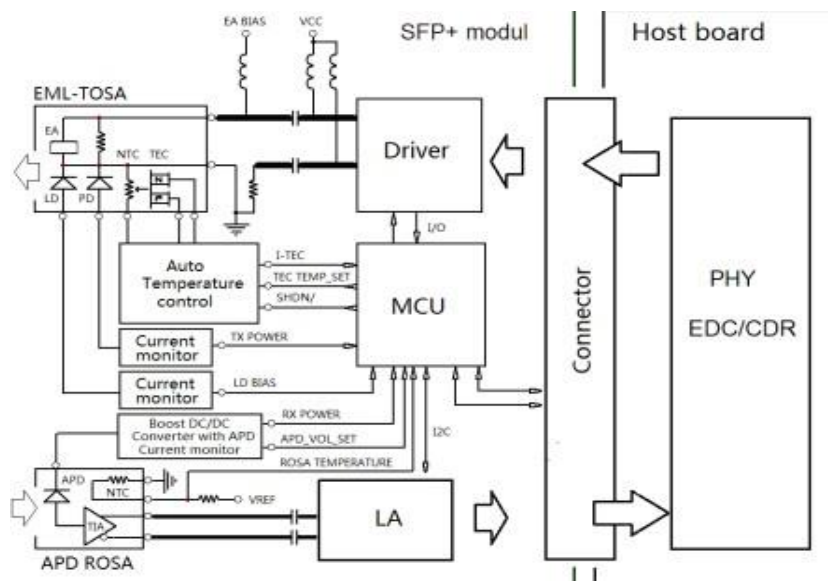

Absolute Maximum Ratings

Parameter	Symbol	Min.	Max.	Unit	Note
Supply Voltage	Vcc	-0.5	4.0	V	
Storage Temperature	Ts	-40	85	°C	
Relative Humidity	RH	0	85	%	
Receiver Damage Threshold	RDth	-7		dBm	

Note: Stress in excess of the maximum absolute ratings can cause permanent damage to the transceiver.

General Operating Characteristics

Parameter	Symbol	Min.	Typ	Max.	Unit	Note
Data Rate	DR		10		Gb/s	
Supply Voltage	Vcc	3.13	3.3	3.47	V	
Supply Current	Iccs			360	mA	
Power Supply Noise Rejection				100	mVp-p	100HZ to 1MHZ
Operating Case Temp.	Tc	0		70	°C	
	Tl	-40		85	°C	

Electrical Characteristics (TOP(C) = 0 to 70 °C, TOP(I) = -40 to 85 °C, VCC = 3.13 to 3.47 V)

Parameter	Symbol	Min.	Typ	Max.	Unit	Note
Transmitter						
Differential data input swing	V _{IN,PP}	120		850	mV _{pp}	
Transmit Disable Voltage	V _D	V _{CC} -0.8		V _{CC}	V	
Transmit Enable Voltage	V _{EN}	V _{EE}		V _{EE} +0.8	V	
Input differential impedance	R _{in}	90	100	110	Ω	
Receiver						
Differential data output swing	V _{out,pp}	340		800	mV _{pp}	
Output rise time and fall time	T _r , T _f	28			Ps	1
LOS asserted	V _{LOS_F}	V _{CC} -0.8		V _{CC}	V	2
LOS de-asserted	V _{LOS_N}	V _{EE}		V _{EE} +0.8	V	2

Notes:

- 20 – 80%. Measured with Module Compliance Test Board and OMA test pattern. Use of four 1's and four 0's sequence in the PRBS 9 is an acceptable alternative.
- LOS is an open collector output. Should be pulled up with 4.7kΩ – 10kΩ on the host board. Normal operation is logic 0; loss of signal is logic 1.

Optical Characteristics (T_{OP(C)} = 0 to 70 °C, T_{OP(I)} = -40 to 85 °C, V_{CC} = 3.13 to 3.47 V)

Parameter	Symbol	Min.	Typ	Max.	Unit	Note
Transmitter						
Center Wavelength	λ _c	1528.77		1563.86	nm	
Center Wavelength (End of Life)	λ _{c_EOL}		λ _c ±100pm			
Ave. output power (Enabled)	P _{AVE}	0		5	dBm	
Side-Mode Suppression Ratio	SMSR	30			dB	
Extinction Ratio	ER	8.2			dB	
RMS spectral width	Δλ			0.3	nm	
Rise/Fall time (20%~80%)	T _r /T _f			50	ps	
Relative Intensity Noise	RIN			-128	dB/Hz	
Output Eye Mask	Compliant with ITU recommendation G.957					
Receiver						
Operating Wavelength	λ	1270		1610	nm	
Receiver Sensitivity	P _{SEN}			-32	dBm	1
Overload	P _{AVE}	-7			dBm	
LOS Assert	P _a	-45			dBm	
LOS De-assert	P _d			-33	dBm	
LOS Hysteresis	P _d -P _a	0.5			dB	

Notes:

- 1) Measured with Light source 1550nm, ER=8.2dB; BER = <10⁻¹² @ PRBS=2²³-1 NRZ

Pin Defintion And Functions



Pin	Symbol	Name/Description
1	VEET [1]	Transmitter Ground
2	Tx_FAULT [2]	Transmitter Fault
3	Tx_DIS [3]	Transmitter Disable. Laser output disabled on high or open
4	SDA [2]	2-wire Serial Interface Data Line
5	SCL [2]	2-wire Serial Interface Clock Line
6	MOD_ABS [4]	Module Absent. Grounded within the module
7	RS0	No connection required
8	RX_LOS [2]	Loss of Signal indication. Logic 0 indicates normal operation
9	RS1	Rate Select 1
10	VEER [1]	Receiver Ground
11	VEER [1]	Receiver Ground
12	RD-	Receiver Inverted DATA out. AC Coupled
13	RD+	Receiver DATA out. AC Coupled
14	VEER [1]	Receiver Ground
15	VCCR	Receiver Power Supply
16	VCCT	Transmitter Power Supply
17	VEET [1]	Transmitter Ground
18	TD+	Transmitter DATA in. AC Coupled
19	TD-	Transmitter Inverted DATA in. AC Coupled
20	VEET [1]	Transmitter Ground

Notes:

1. Module circuit ground is isolated from module chassis ground within the module.
2. should be pulled up with 4.7k – 10k ohms on host board to a voltage between 3.15V and 3.6V.
3. Tx_Disable is an input contact with a 4.7 kΩ to 10 kΩ pullup to VccT inside the module.
4. Mod_ABS is connected to VeeT or VeeR in the SFP+ module. The host may pull this contact up to Vcc_Host with a resistor in the range 4.7 kΩ to 10 kΩ. Mod_ABS is asserted “High” when the SFP+ module is physically absent from a host slot.

Serial Interface for ID and Digital Diagnostic Monitor

The ARDxx12L-CDH2 transceiver support the 2-wire serial communication protocol as defined in the SFP+ MSA. The standard SFP+ serial ID provides access to identification information that describes the transceiver’s capabilities, standard interfaces, manufacturer, and other information. Additionally, This SFP+ transceivers provide an enhanced digital diagnostic monitoring interface, which allows real-time access to device operating parameters such as transceiver temperature, laser bias current, transmitted optical power, received optical power and transceiver supply voltage. It also defines a sophisticated system of alarm and warning flags, which alerts end-users when particular operating parameters are outside of a factory set normal range.

The SFP MSA defines a 256-byte memory map in EEPROM that is accessible over a 2-wire serial interface at the 8 bit address 1010000X(A0h), so the originally monitoring interface makes use of the 8 bit address(A2h), so the originally defined serial ID memory map remains unchanged. The structure of the memory map is shown in Table1.

2 wire address 1010000X (A0h)		2 wire address 1010001X (A2h)	
Address	Information	Address	Information
0~95	Serial ID Defined by SFP MSA (96 bytes)	0~55	Alarm and Warning Thresholds (56 bytes)
96~127	Vendor Specific (32 bytes)	56~95	Calibration Constants (40 bytes)
128~255	Reserved,SFF8079 (128 bytes)	96~119	Real Time Diagnostic Interface (24 bytes)
		120~127	Vender Specific (8 bytes)
		128~247	User Writable EEPROM (120 bytes)
		248~255	Vender Specific (8 bytes)

Table 1. Digital Diagnostic Memory Map (Specific Data Field Descriptions)

Digital Diagnostic Specifications

The ARDxx12L-C(I)DH2 transceivers can be used in host systems that require either internally or externally calibrated digital diagnostics.

Parameter	Symbol	Units	Min.	Max.	Accuracy	Note
Transceiver temperature	DTemp-E	°C	-45	+90	±5°C	1
Transceiver supply voltage	DVoltage	V	2.8	4.0	±3%	
Transmitter bias current	DBias	mA	0	127	±10%	2
Transmitter output power	DTx-Power	dBm	-3	+7	±2dB	
Receiver average input power	DRx-Power	dBm	-34	-5	±2dB	

Notes:

1. Internally measured
2. The accuracy of the Tx bias current is 10% of the actual current from the laser driver to the laser

Typical Interface Circuit

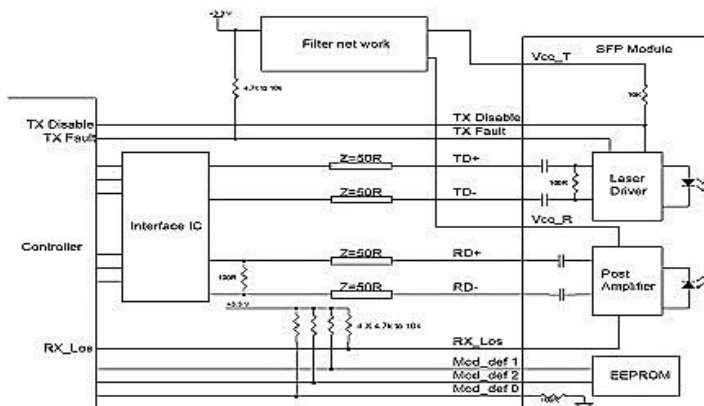

Recommended power supply filter

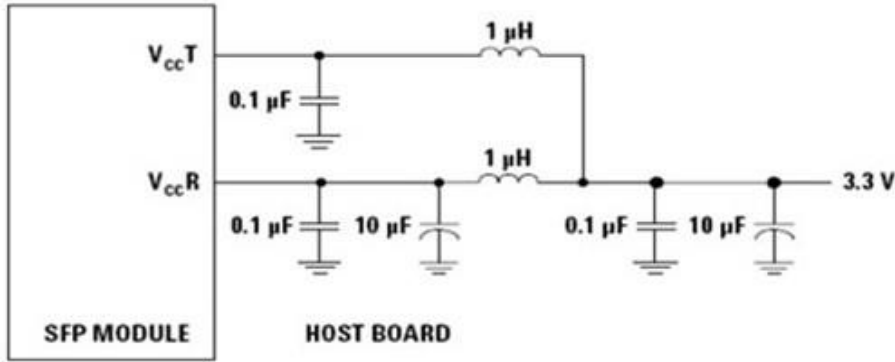

Note:

Inductors with DC resistance of less than 1Ω should be used in order to maintain the required voltage at the SFP input pin with 3.3V supply voltage. When the recommended supply filtering network is used, hot plugging of the SFP transceiver module will result in an inrush current of no more than 30 mA greater than the steady state value

Package Dimensions

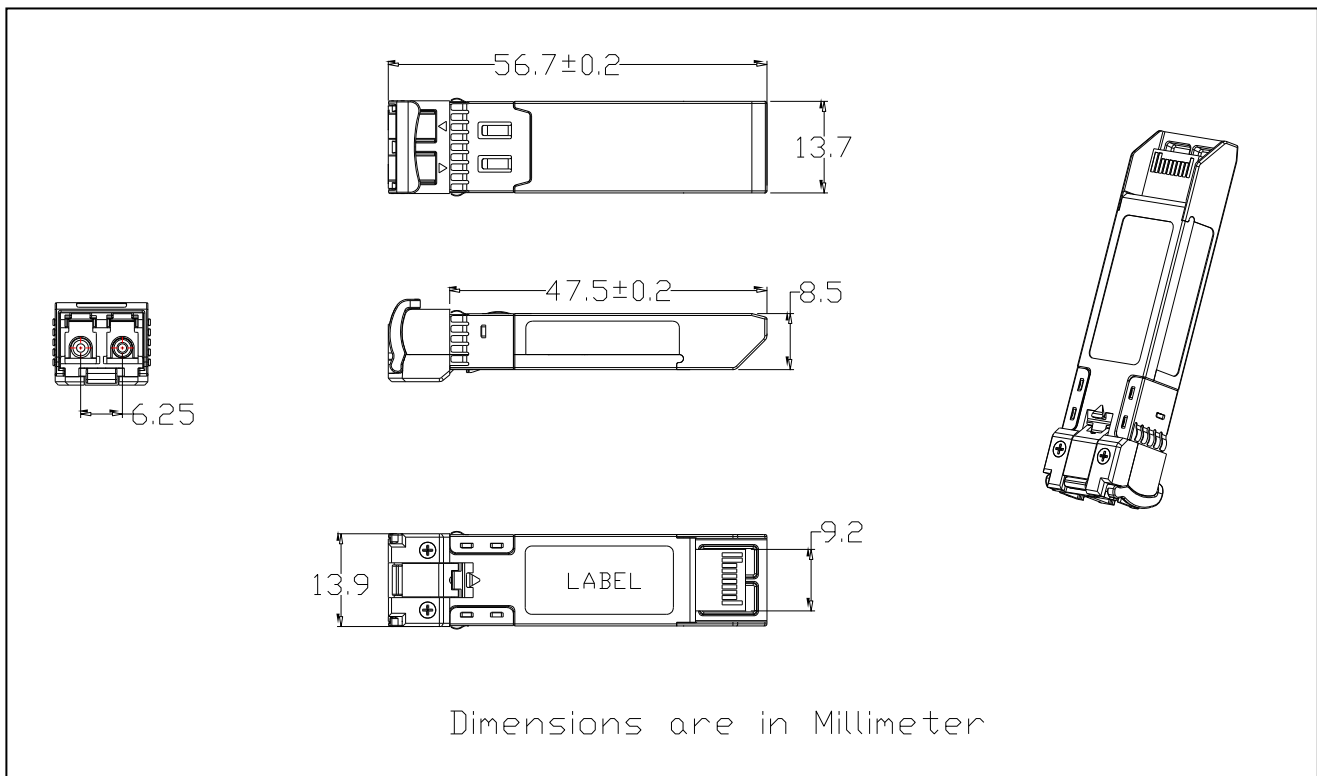

Tolerance without indication is $\pm 0.1\text{mm}$

Ordering Information

Part Number	Description
ARDxx12L-CDH2	SFP,10Gb/s, DWDM wavelengths,80km, 0~70°C, with Digital Diagnostic Monitor
ARDxx12L-IDH2	SFP,10Gb/s, DWDM wavelengths,80km, -40~85°C, with Digital Diagnostic Monitor
xx Means:	Refer to “ Product Channel Selection ”

For More Information

www.arioonet.com